

Dimensions

Compact LoadMount Dimensions															
CAPACITY KG	A	B	C	D	E	F	G	H	I	J	K	L	M	N	OUTLINE DRG
0 - 500	150	175	50	120	35	140	70	15	M12	100	20	20	109	112	13/6773
0 - 1000															
0 - 2000															
0 - 5000	150	215	50	120	35	180	70	15	M12	100	30	20	135	138	13/6774
0 - 10000	170	270	65	130	45	230	90	19	M16	130	40	25	160	164	12/7148

Foundation Plate Dimensions														
CAPACITY KG	THICK	P	Q	R	S	T	U	V	OUTLINE DRG	THICK	W	X	Y	OUTLINE DRG
0 - 500	16	210	185	180	55	140	35	14	23/6894	16	160	185	55	23/6894
0 - 1000														
0 - 2000														
0 - 5000	25	210	225	180	55	180	35	14	25	160	225	55		
0 - 10000	30	250	280	210	70	230	45	18	30	180	280	70		

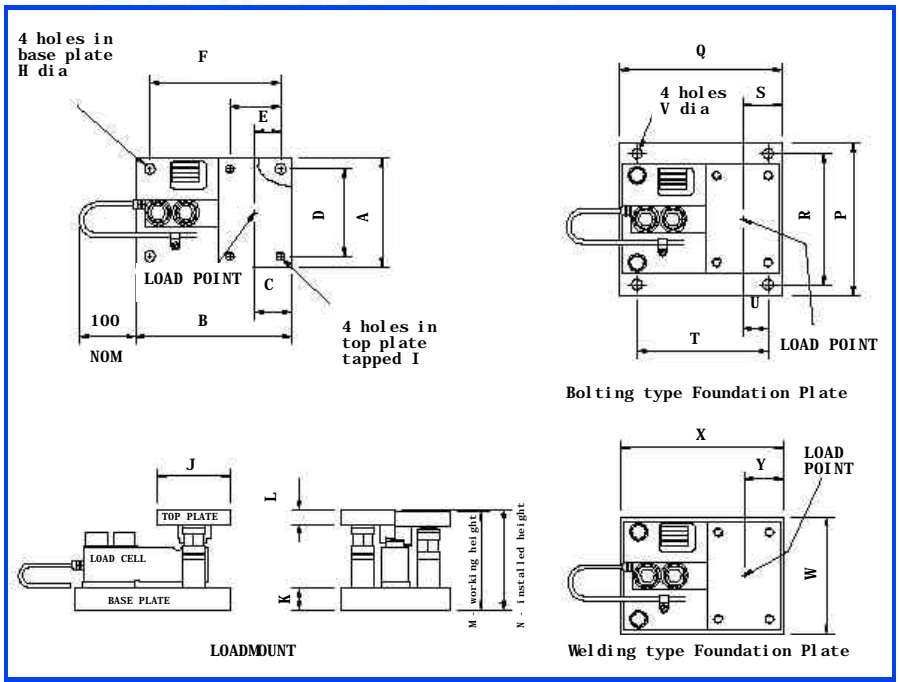

- Installation Notes:**
1. For detailed installation instructions, consult Compact LoadMount Technical Manual and the appropriate Outline Drawing
 2. Allow 250 mm minimum clearance around base plate for tightening fixing bolts
 3. The design of any fixture must not impede the installation or removal of the load cell or its fasteners
 4. Ensure access to jacking screws

NOVA WEIGH



Compact LoadMount

The Complete Vessel Weighing System



NOVA WEIGH



European Head Office - United Kingdom BS EN ISO 9001:2000 Cert No: FM 11445

Nova Weigh Limited, Colemeadow Road, Redditch, Worcestershire B98 9PB
 Tel: +44 (0)1527 67557 Fax: +44 (0)1527 60213 e-mail: sales@novaweigh.co.uk Website: www.novaweigh.co.uk

Nova Weigh's policy of constant product development dictates that we may alter specifications and or the appearance of our product range without notice.

Compact LoadMount

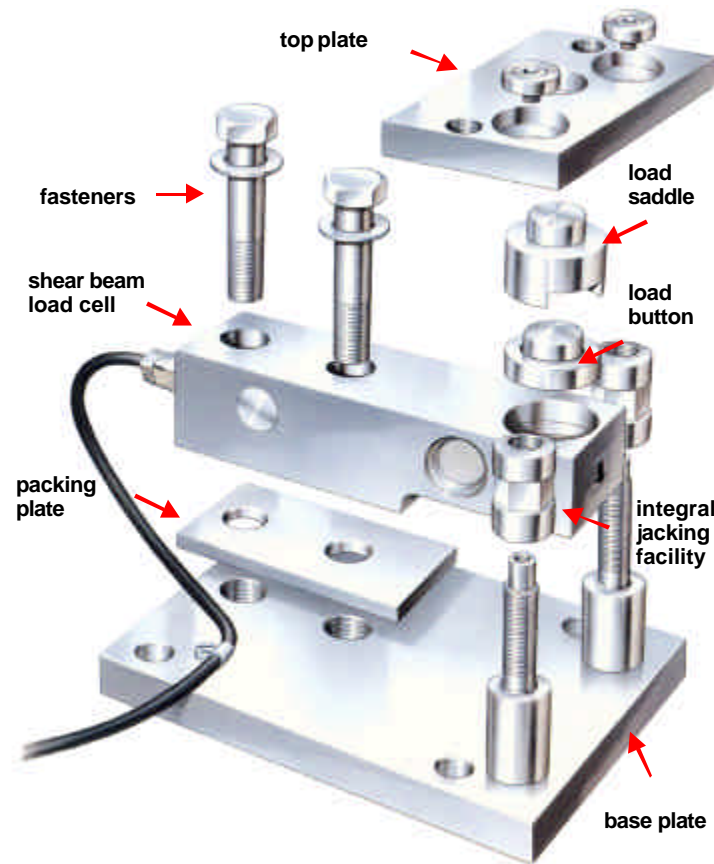

This diagram explains the principles of construction and reference should be made to outline drawings for fixing details

Use of Dummy LoadMount

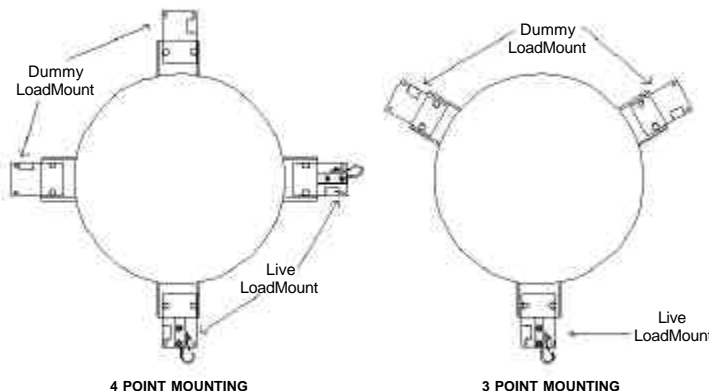

Total Vessel Weighing

Choosing Nova Weigh's Compact LoadMount is the best possible starting point in the design of an accurate and reliable vessel weighing system.

Thousands of LoadMounts are at work in plants all over the world providing critical process control and inventory monitoring in industries such as pharmaceuticals, chemicals, beverages and food processing. All this application experience has resulted in a product that is simple to install, precise and reliable - however tough the application.

At the heart of each Compact LoadMount is a precision shear beam load cell. The load cell can be made from alloy steel or stainless steel according to environmental conditions. Side loads have no effect on the performance of this cell and no tie-bars or constrainters are required. Overturning protection is built into the mount.

Thermal expansion/contraction of the vessel can take place without weighing errors.

Mounts are either in zinc plated, yellow passivated, mild steel or 304 stainless steel. Mounts in 316 stainless can also be supplied. The hygienic design meets the needs of the food and pharmaceutical industries and ATEX/CENELEC certification for Gas and Dust Zones mean that the cells can be used within hazardous areas.

Integral Jacking makes load cell installation simple

Installing the load cells into the locked-up Compact LoadMounts is a simple job. Then the jacking screws are used to gently lower the vessel to its working height. If there is ever a need to remove a load cell, then the same jacking screws can be used to lift the load from the cell allowing its removal and replacement. Up to 25% of the rated load of the mount can be lifted in this way.

Locked-up Assembly - no 'installation dummies' required

Compact LoadMount is shipped 'locked-up' and without a load cell fitted. There are no loose parts to assemble and align during installation and no risk of damage to the load cell. No 'dummy load cells' are required - unlike other vessel weighing systems.

The vessel is simply installed onto the locked-up mounts ready for commissioning after site erection is completed.

Setting Height Collars supplied as standard



'Setting Height Collars' are supplied with every mount. These can be used to set the mount to its precise working height before the load cells are fitted. This can be important when pipework must be installed with the vessel at its working height.

'Dummy LoadMount' saves cost

When a modest weighing accuracy is sufficient, perhaps for inventory monitoring, then a vessel can be supported on a combination of 'live' and 'dummy' mounts. The 'dummy mounts' are Compact LoadMounts without the load cell and associated parts fitted. If the client wishes later to enhance the performance of the system then load cells can be easily retrofitted.

Options

Foundation plates (welded or bolted type) save time and expense on site by avoiding the need to accurately pre-drill supporting steel work or the floor surface.



Thermal pads are fitted when high process temperatures would otherwise cause the load cell to be exposed to widely fluctuating temperatures.

Shim packs are useful when a vessel has four or more supports. The shims are used to adjust the height of the mounts. A set of shims allows up to 5 mm adjustment (total).



Static electricity may be a problem when handling dry powder or granular material. Potential equalisation straps provide electrical continuity across the mount ensuring static charges are grounded.

NOVA WEIGH