

SAVAR 4100

A PALLET TRUCK SCALE FROM THE LEADER IN MOBILE WEIGHING



RAISES EFFICIENCY AND SIMPLIFIES LOGISTIC PROCESSES, SAVES TIME AND SPACE

FOR CHECKING INCOMING GOODS, DOSING AND MIXING, DETERMINING SHIPPING WEIGHTS, COUNTING PARTS AND DATA COMMUNICATION

PARTS COUNTING PROGRAMME WITH PIECE WEIGHT SAMPLING

THREE DIFFERENT COMMUNICATION PROTOCOLS FOR DATA TRANSFER TO HANDHELD TERMINAL, PC OR WMS

HIGH ACCURACY: MAXIMUM ERROR 0.1% OF THE APPLIED WEIGHT

ERGONOMIC DESIGN: LEVER FUNCTIONS WHICH CAN BE OPERATED RIGHT OR LEFT-HANDED; WEIGHS ONLY 99 KG

EASILY EXCHANGEABLE BATTERY PACK FOR CONTINUOUS USE; CHARGER INCLUDED

FUNCTIONS

- ◆ Automatic and manual zero correction
- ◆ Gross/net weighing
- ◆ Automatic and manual tare
- ◆ Totaling with sequence number
- ◆ Code entry (6-digit)
- ◆ Piece counting by sampling
- ◆ Piece counting by entry of piece weight
- ◆ Two RS232 Outputs
- ◆ Internal clock
- ◆ Error messages in display
- ◆ Automatic switch-off after 30 minutes of non-use
- ◆ kg / lb toggle



User-friendly digital indicator

RAVAS

DIMENSIONS

A	Fork length	:	1150 mm
B	Fork width	:	170 mm
C	Minimum fork height	:	85 mm
	Minimum space between floor and forks	:	22 mm
D	Maximum fork height	:	205 mm
	Lifting height	:	120 mm
E	Width over forks	:	540 mm
F	Height to top indicator	:	770 mm

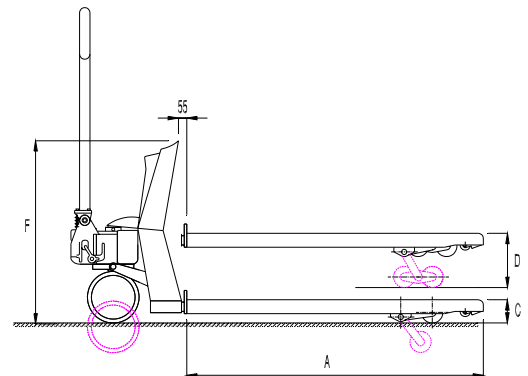

PRECISION STANDARD VERSION

Max. inaccuracy : 0.1% of the applied weight

Graduation : multirange
 0 - 200 kg: graduation 0.2 kg
 200 - 500 kg: graduation 0.5 kg
 500 - 2200 kg: graduation 1 kg

PRECISION APPROVED FOR TRADE VERSION CLASS III

Multirange or options possible:

- 1000 divisions : 1.0/1000 kg or 2.0/2000 kg
- 2000 divisions : 0.5/1000 kg or 1.0/2000 kg
- 3000 divisions : 0.1/300 kg or 0.2/600 kg or 0.5/1500 kg

STANDARD SPECIFICATIONS

Weighing capacity	: 2200 kg
Display	: LCD, height 18 mm, backlight
Keypad	: 5 function keys, on / off key
Protection class	: load cells and cabling IP67, indicator IP65
Steering wheels	: rubber
Loading wheels	: polyurethane, single
Colour	: red (RAL 3000), epoxy painted
Own weight	: 99 kg
Battery	: 12 Vdc / 1.2 Ah, exchangeable; delivery including separate charging module
Battery life	: 35 hours, low voltage indication
Charger	: 230 Volt / 12 Vdc - 300 mA
Charging time	: approximately 6 hours
Pump	: quick lift
For approved version class III	: European approval no. T2782 switch-off of display when tilting more than 2° : memory for last 10 entered tare values, codes and piece weights : no kg / lb toggle, no backlight and no piece counting by sampling : specifications can differ from standard specifications

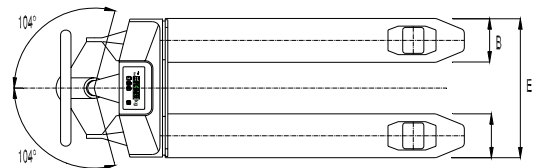

OPTIONS WEIGHING SYSTEM *

Approved version	: legal for trade OIML class III
Smaller graduation	: for a more precise or finer multirange indication (and with reduced capacity)
RS232 output	: for data communication (e.g. with printer)
Built-in printer	: thermal or matrix; for printing weighing data on-site
Separate printer	: Star DP 8340
Push buttons	: for easy operation when wearing gloves
Relay output	: to activate shut-off valve or visual/audio signals
Pivoting indicator	: plastic or metal enclosure for reading display from all angles
Extra exchangeable battery	: for continuous use
Explosion proof version	: ATEX certified
Reference scale	: to define accurate piece weights
Bluetooth	: radiographic data transmission; for wireless communication with printer or PC

OPTIONS HAND PALLET TRUCK *

- Stainless steel version
- Stainless steel fork shoes
- Galvanised version
- Recess frame
- Steering wheels in polyurethane or nylon
- Loading wheels in nylon and/or tandem
- Handbrake
- Footbrake
- Capacity 3000 kg (graduation 1 kg)
- Fork length from 950 mm to 2400 mm
- Width over forks 700 mm and special widths

* For special options the specifications can differ from standard specifications

RAVAS

RAVAS Europe B.V.

P.O. Box 2023
 5300 CA Zaltbommel
 The Netherlands

+31 - 418 - 51 52 20

+31 - 418 - 51 53 20

info@ravas.com

www.ravas.com

Rev. 27.07.05.1