

**SPIROFLOW**

AERO MECHANICAL CONVEYORS

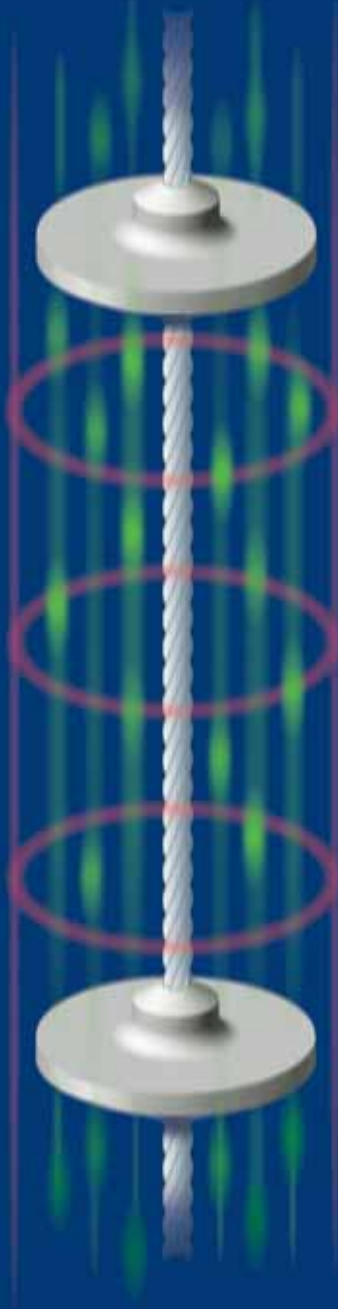

---

SUPERIOR IN DESIGN, OUTSTANDING IN PERFORMANCE.

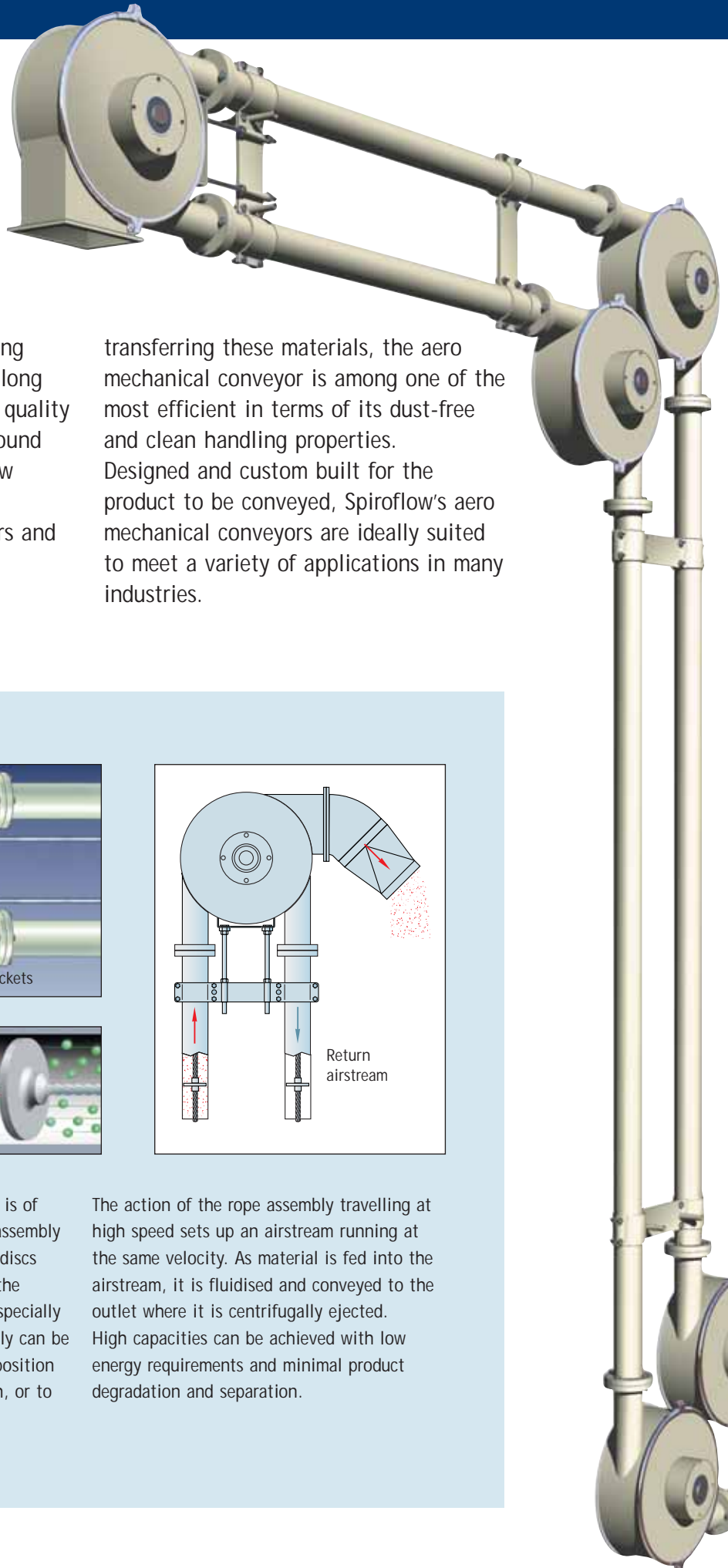

In the solids handling and processing industries, the name Spiroflow has long been synonymous with innovation, quality and customer service. Operating around the world on a daily basis, Spiroflow equipment can be seen in every conceivable situation where powders and granular materials are handled. Of the many systems designed for

transferring these materials, the aero mechanical conveyor is among one of the most efficient in terms of its dust-free and clean handling properties. Designed and custom built for the product to be conveyed, Spiroflow's aero mechanical conveyors are ideally suited to meet a variety of applications in many industries.

## Principle of operation

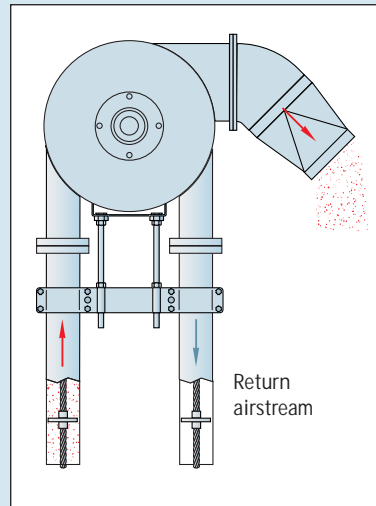
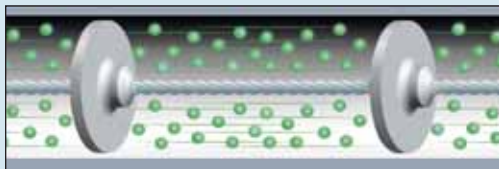
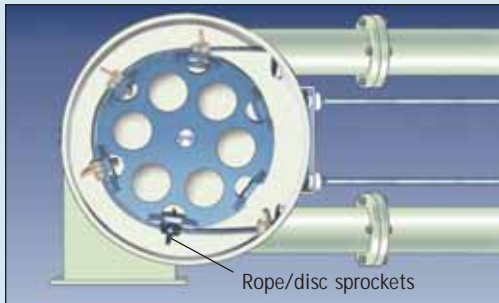

Spiroflow's aero mechanical conveyor is of tubular design in which a wire rope assembly with accurately spaced polyurethane discs move at high speed. At each end of the conveyor, the rope assembly runs in specially designed sprockets. The drive assembly can be located in either the top or bottom position of the conveyor, depending on length, or to suit plant requirements.

The action of the rope assembly travelling at high speed sets up an airstream running at the same velocity. As material is fed into the airstream, it is fluidised and conveyed to the outlet where it is centrifugally ejected. High capacities can be achieved with low energy requirements and minimal product degradation and separation.

# Conveyors... proven design, robust construction,

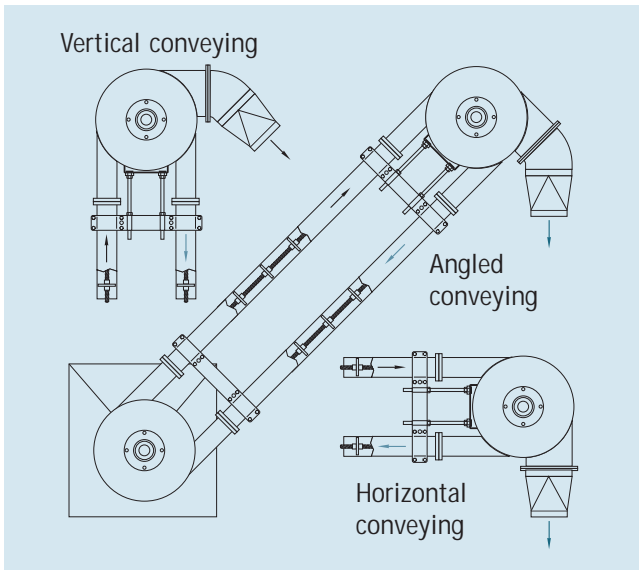

One of the most significant features of the aero mechanical conveying system is its ability to convey materials at any angle between 0° and 90° without loss of capacity.

The range of operating configurations is virtually limitless - enabling the widest choice of system layout options using standard components to suit customer requirements and available factory environment.

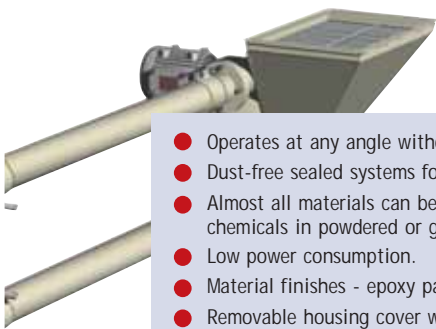

- Operates at any angle without any loss of capacity.
- Dust-free sealed systems for ultrafine powders.
- Almost all materials can be conveyed - ideal for food products and chemicals in powdered or granular form.
- Low power consumption.
- Material finishes - epoxy painted or stainless steel.
- Removable housing cover with optional interlock for easy cleaning.

## Materials testing

The range and diversity of powder and granular materials that can be handled by aero mechanical means is enormous. While many products may appear to be similar in content, their characteristics can vary considerably under dynamic operating conditions.

Spiroflow's large database of material flow has been accumulated over many years of testing in both laboratory and actual test rig situations. New materials are subjected to the same analytical process, evaluated and logged into the database. This provides all the parameters for optimum performance to be included at the initial project design stage.



## Typical throughputs

The table below shows estimated AMC conveying rates in tons per hour based on continuously metered feed. When feeding from a bag dump, the rate may reduce by 10% - 40% depending on the material flow characteristics.

Product	Model		
	PC3	PC4	PC5
Barley	16	33	66
Carbon black	6	12	24
Coffee Beans	6	12	24
Desiccated Coconut	3	6	12
Fiberglass	7	14	28
Flour	6	12	24
Gypsum	15	30	60
Iron Powder	10	20	40
Lime-hydrated	5	10	20
Milk Powder	5	10	20
Oats	10	20	40
Polyethylene	12	24	48
PVC pellets	10	20	40
PVC powder	13	26	52
Sand	24	48	96
Sodium carbonate	9	18	36
Sugar (granulated)	20	40	80
Tea	6	12	24
Titanium Dioxide	5	10	20
Wheat	33	66	132
Zinc Oxide	6	12	24

Model	PC3	PC4	PC5
Tube size (OD) mm	75	100	125
Particle size (max)	10	15	15
Conveyor length (metres) max			
Vertical	15	15	15
Horizontal	18	18	18
Cornered	12	12	12
Rope speed (metres per min)	228	305	365

# optimum performance.

## Layout Options

Designed to meet the majority of applications, Spiroflow's basic AMC configurations are shown here. Many other layouts can be designed to suit customers' requirements.

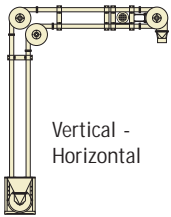

Vertical - Horizontal

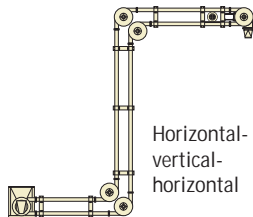

Horizontal-vertical-horizontal

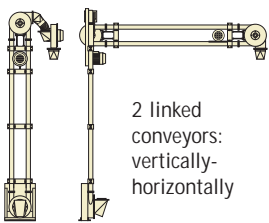

2 linked conveyors: vertically-horizontally

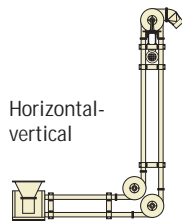

Horizontal-vertical

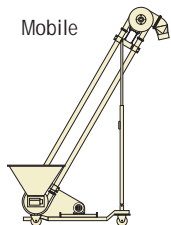

Mobile

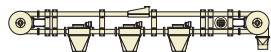

Horizontal distribution system

## New developments

As with all conveyor systems, routine maintenance reduces breakdowns and wear on machines. Three new patented devices are now available for Spiroflow aero mechanical conveyors to insure smooth and trouble-free operation. Extensive trials have shown that rope life can be increased by up to 40% by use of these devices. Choice of unit depends on length of conveyor, usage and type of product being conveyed.

- \* Rope tension monitor - alerts user to need for rope tensioning.
- \* Automatic monitoring and tensioning device.

## Features & Accessories



Inlet chute with aeration device



Standard disc material in USDA accepted polyurethane



Pneumatic baffle provides control of flow into conveyor (free flowing materials only).

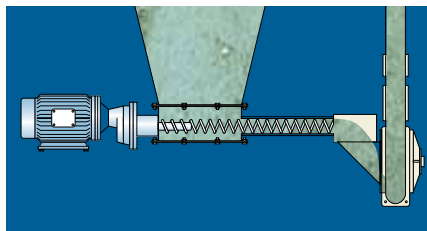

When the headroom is very low, a screw conveyor can be used to bring material into the chute of the aero mechanical conveyor.

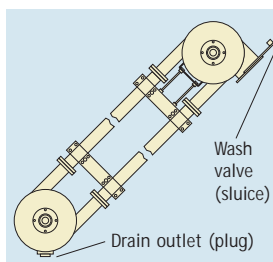

In food and pharmaceutical applications, the machine can be washed with water or other cleaning solution (CIP). A valve is necessary at the top outlet and a drain at the bottom. Removable housing covers are also available for easy maintenance.



In sack emptying operations, a dust hood is often necessary. A sack compaction device may also be supplied.

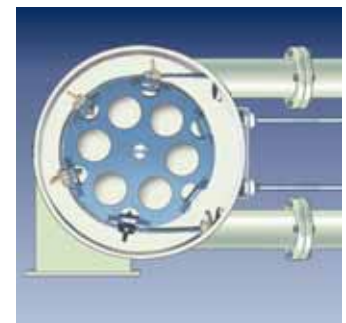

Material finishes can be epoxy painted or stainless steel.

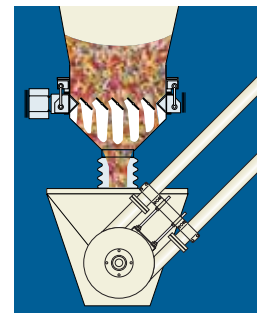

Bin Activator/meter feeder

# Applications

## Applications

Consistent performance and operational reliability have endeared aero mechanical conveyors to a wide audience of industries.

From the seemingly simple task of transferring food

ingredients to the abrasive and corrosive nature of conveying chemical industry products, AMCs are well-equipped to handle many kinds of products with ease.



Feeding bagged material into an elevated hopper.



AMC elevating material from a transition hopper fed by two bulk bag dischargers via spiral conveyors.



AMC designed for handling titanium dioxide. The aero mechanical conveyor is the only effective method of handling this type of product.



An aero mechanical conveyor elevating chemicals. Discharge heights can be specified to suit individual specifications.



Mobile aero mechanical conveyors are used extensively both in and out of the factory environment.



Bulk bag discharger and AMC loading road tanker.



Bulk bag discharger and AMC loading rail car.



## DESIGN

We have an experienced team of mechanical and electrical engineers with a vast collective knowledge of solids handling, geared to handle your project quickly and efficiently, whether you need a single filling station or a complete powder handling system.

## TESTING

Our fully equipped test facility, which is at your disposal, assesses performance of our machinery on your particular material. On-site trials can also be arranged if preferred.

## AFTER SALES

At Spiroflow, we firmly believe that after sales service forms an integral part of the product. Over 70% of our business comes from existing customers, whom we work with as partners from the moment of placing an order and throughout the equipment's operational life.

## MANUFACTURING

Our manufacturing unit, to which we welcome visits by our customers at any time, guarantees your order is processed efficiently and to our high quality standards. We have manufacturing facilities in the USA and the UK.

### Other equipment in the Spiroflow range:

- Flexible screw conveyors
- Bulk Bag filling & weighing machines
- Sack packing systems
- Vacuum conveyors
- Sack, drum, IBC and octabin emptiers
- Silo and hopper discharge aids
- Bulk bag dischargers
- Batch and continuous weighing systems
- Continuous mixing systems



Technical papers are available covering most Spiroflow products and may be obtained on request.



Further information concerning Spiroflow products and services can be found by visiting our website.