

SHAPA Technical Bulletin No.10

**SIZING
OF
EXPLOSION RELIEF VENTS**

Sizing of Explosion Relief Vents

By
Mike Ward
Fike UK Ltd

On behalf of The SHAPA Technical Committee

Introduction

Many industries handle materials with the potential for a dust explosion and there are statutory requirements to take both preventative and protective measures to protect personnel and plant equipment.

For many years the most common and popular method of protection has been explosion venting. In its simplest form, a vent is an aperture in the top or side of a vessel to provide a means of pressure relief during an explosion. As well as providing sufficient relief area, the vent aperture must be sealed with a water/dust tight cover or bursting panel of suitable construction and ATEX certification – see Picture 1.

Although calculating the size of the vent required is relatively straightforward, care must be taken to ensure safe and reliable design. The German code of practice VDI 3673 (2002) “Pressure venting of Dust Explosions” and draft EN standard prEN14491 are widely used.



Picture 1

Calculations

The basic sizing equations for a reduced explosion pressure of less than 1.5 bar are:

$$A = B (1 + C \times \log_{10}(L/D_E))$$

with

$$B = (3.264 \times 10^{-5} \times P_{\max} \times K_{st} \times P_{red}^{-0.569} + 0.27 \times (P_{stat} - 0.1) \times P_{red}^{-0.5}) \times V^{0.753}$$

and

$$C = (-4.305 \times \log_{10}P_{red} + 0.758)$$

where

A = Area of vent in m²

V = Volume of vessel in m³ (between 0.1m³ and 1000m³)

K_{st} = explosion pressure rate of rise in bar.m/sec*

P_{max} = Maximum explosion pressure in bar* (between 5 and 10 bar for

K_{st} < 300 bar.m/sec and between 5 and 12 bar for K_{st} up to 800 bar.m/sec)

P_{red} = reduced explosion pressure in bar

P_{stat} = static opening pressure of burst panel in bar (between 0.1 and 1.0 bar)

L/D_E = length to diameter ratio (up to 20)

*Test data from explosion testing of material being handled

L/D_E is a measure of the 'shape' of a vessel and turns out to be an important design parameter. Vessels that are near to cubic (L/D_E approximately 1) require relatively little vent area, whilst elongated vessels may need double, treble or perhaps even more vent area in comparison. For rectangular or cylindrical vessels, L/D_E can be calculated directly from the physical dimensions (with D = 2 × (CSA / π)^{0.5} in the case of rectangular).

If the vessel consists of a cylindrical and conical part, or if the vent relief is at the side rather than the top, then L/D_E is estimated through the effective flame length (maximum distance the flame must travel to exit the vessel) and the effective volume (volume the flame travels through).

Example 1 – sugar silo

The maximum distance a flame may travel to exit is from the bottom of the sugar silo to the top (6m). However, VDI 3673 (2002) acknowledges that flame does not spread in an optimum fashion in a cone and allows just one third of the cone height to be used instead.

Effective flame length (L_{eff}) = cylinder height + 1/3 cone height
= 4m + 0.667m = 4.667m

The effective volume the flame passes through is taken to be the cylinder volume plus one third of the cone volume.

Effective volume (V_{eff}) = $(\pi \times 0.9^2 \times 4) + (2 \times \pi/3 \times (0.9^2 + (0.9 \times 0.25) + 0.25^2)/3) = 10.179 + 0.766 = 10.945 \text{ m}^3$

Effective cross section = $V_{eff} / L_{eff} = 10.945 / 4.667 = 2.345\text{m}$

Effective diameter = $2 \times (2.345/\pi)^{0.5} = 1.728\text{m}$

Hence $L/D_E = 4.667/1.728 = 2.70$

Note that the effective volume is only used in the estimation of L/D_E . The total silo volume will be used for the vent area sizing as follows.

$K_{st} = 138 \text{ bar.m/s}$ $P_{max} = 8.5 \text{ bar}$ $P_{red} = 0.35 \text{ bar}$ $P_{stat} = 0.1 \text{ bar}$

hence $B = (3.264 \times 10^{-5} \times 8.5 \times 138 \times 0.35^{-0.569}) \times (\pi \times 0.9^2 \times 4 + (2 \times \pi/3 \times (0.9^2 + (0.9 \times 0.25) + 0.25^2)))^{0.753} = 0.0696 \times (12.477)^{0.753} = 0.466$

and $C = (-4.305 \times \log_{10} 0.35 + 0.758) = 2.721$

so vent area = $0.466 (1 + 2.71 \times \log_{10}(2.70)) = 1.01\text{m}^2$

Finally, the venting efficiency can be added for a particular type or design of vent. Although burst panels are generally regarded as 100% efficient, this is only true if they are less than 10Kg/m^2 in weight and fitted on vessels with a K factor (defined as $A/V^{0.753}$) of less than 0.07. For the sugar silo, $K = 1.01/12.477^{0.753} = 0.151$ and the venting efficiency must therefore be obtained from the manufacturer – in this case 91%.

The actual vent area to be fitted = $1.01/0.91 = 1.11\text{m}^2$

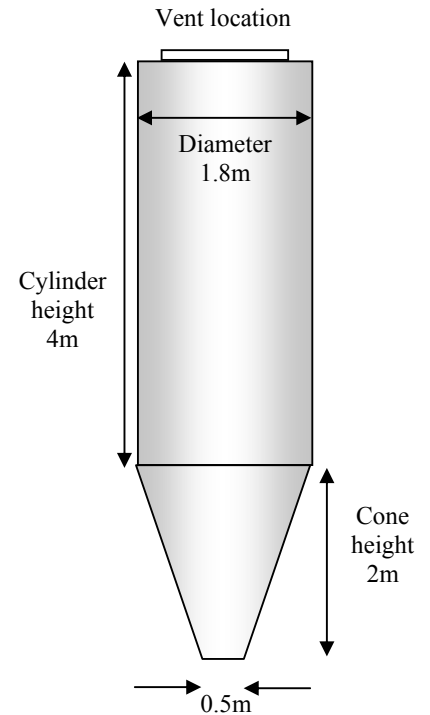

Example 2 – rectangular filter extracting coal dust

Two vents are to be located on the filter side, below the bottom of the filter bags. The longest flame path in the ‘dirty’ section is therefore from the bag plenum to the bottom of the vents.

Effective flame length (L_{eff}) = 3m

Although it is usual to subtract the volume of the filter bags to determine the vent area required, the effective volume is simply the rectangular section to the bottom the vent.

Effective volume (V_{eff}) = $3 \times 5 \times 1.9 = 28.5\text{m}^3$

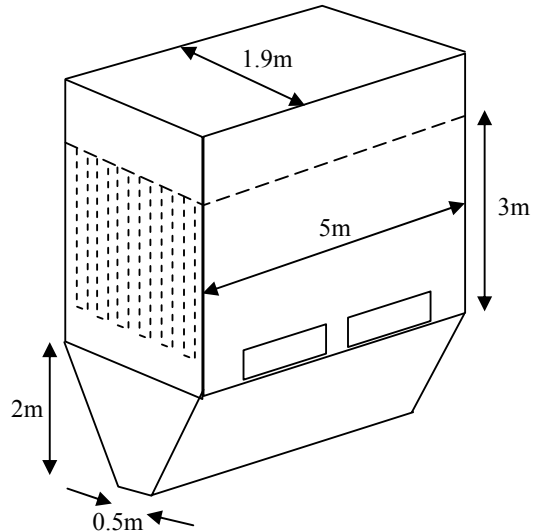

Effective cross section = $V_{eff} / L_{eff} = 28.5 / 3 = 9.5\text{m}$

Effective diameter = $2 \times (9.5/\pi)^{0.5} = 3.478\text{m}$

Hence $L/D_E = 3/3.478 = 0.863$

Since the result is less than 1, $L/D = 1$ will be used for the vent determination.

There are 260 filter bags, 2.5m long and 150mm in diameter, so the filter bag volume = $260 \times (2.5 \times \pi \times 0.15^2/4) = 11.49\text{m}^3$

Hence the ‘dirty’ volume of the filter = $3 \times 5 \times 1.9 + 5 \times 2 \times (1.9 + 0.5)/2 - 11.49 = 28.5 + 12 - 11.49 = 29.01\text{m}^3$

$K_{st} = 85 \text{ bar.m/s}$ $P_{max} = 6.5 \text{ bar}$ $P_{red} = 0.2 \text{ bar}$ $P_{stat} = 0.1 \text{ bar}$

$B = (3.264 \times 10^{-5} \times 6.5 \times 85 \times 0.2^{-0.569}) \times 29.01^{0.753} = 0.0451 \times 12.63 = 0.569$

and $C = (-4.305 \times \log_{10}0.2 + 0.758) = 3.767$

so vent area = $0.569 (1 + 3.767 \times \log_{10}(1)) = 0.569\text{m}^2$

K factor ($A/V^{0.753}$) = $0.569/29.01^{0.753} = 0.045$ (less than 0.07) and the venting efficiency may be taken as 100%.

Hence two vents are required, 0.285m^2 minimum each.

Other Considerations

Other items for consideration in vent design:

- Select vent type appropriate for the operating conditions (vacuum rating, high temperature, pressure pulsing etc) and only use fully validated ATEX certified vents
- Check vent efficiency figure when K factor greater than 0.07
- Use electrical interlocks on vent opening to cause automatic plant shutdown
- For vessels situated inside the building, seek specialist advice on duct effect or fit flameless venting devices

Conclusion

Explosion venting system designers must take recently developed design standards into consideration in order to ensure that the calculated relief area and selected venting devices are compliant with legislative requirements. This will include the determination of venting efficiency and incorporate it in the overall design.

In particular, the use of 'own design' vent membranes and doors is no longer acceptable unless certified by explosion testing in conjunction with a notified body.

Michael Ward, M.A. is Explosion Protection Specialist with Fike UK, 35 Earl Street, Maidstone, Kent, ME14 1PF. Tel 01622 677081 Fax 01622 685737